



12P HEX IP



User Manual



©2022 ADJ Products, LLC all rights reserved. Information, specifications, diagrams, images, and instructions herein are subject to change without notice. ADJ Products, LLC logo and identifying product names and numbers herein are trademarks of ADJ Products, LLC. Copyright protection claimed includes all forms and matters of copyrightable materials and information now allowed by statutory or judicial law or hereinafter granted. Product names used in this document may be trademarks or registered trademarks of their respective companies and are hereby acknowledged. All non-ADJ Products, LLC brands and product names are trademarks or registered trademarks of their respective companies.

ADJ Products, LLC and all affiliated companies hereby disclaim any and all liabilities for property, equipment, building, and electrical damages, injuries to any persons, and direct or indirect economic loss associated with the use or reliance of any information contained within this document, and/or as a result of the improper, unsafe, insufficient and negligent assembly, installation, rigging, and operation of this product.

DOCUMENT VERSION



Due to additional product features and/or enhancements, an updated version of this document may be available online.

Please check www.adj.com for the latest revision/update of this manual before beginning installation and/or programming.

Date	Document Version	Software Version	DMX Channels	Notes
05/25/2018	1	1.04	6/7/8/13	Initial Version
01/09/2020	1.2	N/C	No Change	3-pin connection replaced with 5-pin
09/03/2020	1.3	1.08	No Change	Updated primary/secondary mode
02/19/2021	1.4	1.09	No Change	Updated system menu
06/23/2021	1.5	N/C	No Change	Approvals added to manual
06/17/2022	1.6	N/C	No Change	Updated specifications and IP Notice; added RDM

Europe Energy Saving Notice

Energy Saving Matters (EuP 2009/125/EC)

Saving electric energy is a key to help protecting the environment. Please turn off all electrical products when they are not in use. To avoid power consumption in idle mode, disconnect all electrical equipment from power when not in use. Thank you!

TABLE OF CONTENTS

Introduction	4
Limited Warranty (USA Only)	5
Warranty Registration Features Installation	6
Safety Precautions	7
IP Notice	9
Layout	10
Remote Device Management (RDM)	11
DMX Set Up	12
DMX Addressing	13
DMX Traits	14
Color Macro Chart	16
System Menu (V1.04)	18
System Menu (V1.07)	20
Operating Instructions	22
Primary-Secondary Configuration Multiple Unit Power Linking	26
Dimmer Mode Chart Dimmer Curve Chart	27
Dimensional Drawing	28
Trouble Shooting Cleaning	29
Specifications	30

INTRODUCTION

Unpacking: Thank you for purchasing the 12P Hex IP by ADJ Products, LLC. Every device has been thoroughly tested and has been shipped in perfect operating condition. Carefully check the shipping carton for damage that may have occurred during shipping. If the carton appears to have been damaged, carefully inspect your fixture for any damage and be sure all accessories necessary to operate the unit have arrived intact. In the event that damage has been found or parts are missing, please contact our toll free customer support number for further instructions. Do not return this unit to your dealer without first contacting customer support.

Introduction: This device is a DMX intelligent, IP rated LED par fixture. This fixture can be used as a stand alone device or connected in a primary/secondary configuration. This par has five operating modes: RGBWA + UV dimmer mode, Static Color mode, Auto Run mode, Color Macro mode, and DMX Control. ***This product is intended for use by professionally trained personnel only, and is not suitable for private use.***

These instructions contain important safety information regarding the use and maintenance of this unit. Please keep this manual with the unit for future reference.

Customer Support: Contact ADJ Service for any product related service and support needs. Also visit forums.adj.com with questions, comments or suggestions.

Parts: To purchase parts online visit:

<http://parts.adj.com> (US)

<http://www.adjparts.eu> (EU)

ADJ SERVICE USA - Monday - Friday 8:00am to 4:30pm PST

Voice: 800-322-6337 | Fax: 323-582-2941 | support@adj.com

ADJ SERVICE EUROPE - Monday - Friday 08:30 to 17:00 CET

Voice: +31 45 546 85 60 | Fax: +31 45 546 85 96 | support@adj.eu

ADJ PRODUCTS LLC USA

6122 S. Eastern Ave. Los Angeles, CA. 90040

323-582-2650 | Fax 323-532-2941 | www.adj.com | info@adj.com

ADJ SUPPLY Europe B.V

Junostraat 2 6468 EW Kerkrade, The Netherlands

+31 (0)45 546 85 00 | Fax +31 45 546 85 99

www.americandj.eu | info@americandj.eu

ADJ PRODUCTS GROUP Mexico

AV Santa Ana 30 Parque Industrial Lerma, Lerma, Mexico 52000

+52 (728) 282-7070

CAUTION! There are no user serviceable parts inside this unit. Do not attempt any repairs yourself, as doing so will void your manufacturer's warranty. In the unlikely event your unit may require service, please contact ADJ Products, LLC.

Do not discard the shipping carton in the trash. Please recycle when ever possible.

LIMITED WARRANTY (USA ONLY)

- A. ADJ Products, LLC hereby warrants, to the original purchaser, ADJ Products, LLC products to be free of manufacturing defects in material and workmanship for a prescribed period from the date of purchase (see specific warranty period on reverse). This warranty shall be valid only if the product is purchased within the United States of America, including possessions and territories. It is the owner's responsibility to establish the date and place of purchase by acceptable evidence, at the time service is sought.
- B. For warranty service, you must obtain a Return Authorization number (RA#) before sending the product back—please contact ADJ Products, LLC Service Department at 800-322-6337. Send the product only to the ADJ Products, LLC factory. All shipping charges must be prepaid. If the requested repairs or service (including parts replacement) are within the terms of this warranty, ADJ Products, LLC will pay return shipping charges only to a designated point within the United States. If the entire instrument is sent, it must be shipped in its original package and packaging material. No accessories should be shipped with the product. If any accessories are shipped with the product, ADJ Products, LLC shall incur no liability whatsoever for loss of or damage to any such accessories, nor for the safe return thereof.
- C. This warranty is void if the product serial number and/or labels are altered or removed; if the product is modified in any manner which ADJ Products, LLC concludes, after inspection, affects the reliability of the product; if the product has been repaired or serviced by anyone other than the ADJ Products, LLC factory unless prior written authorization was issued to purchaser by ADJ Products, LLC; if the product is damaged because it was not properly maintained as set forth in the product instructions, guidelines and/or user manual.
- D. This is not a service contract, and this warranty does not include maintenance, cleaning, or periodic check-up. During the period specified above, ADJ Products, LLC will replace defective parts at its expense with new or refurbished parts, and will absorb all expenses for warranty service and repair labor by reason of defects in material or workmanship. The sole responsibility of ADJ Products, LLC under this warranty shall be limited to the repair of the product, or replacement thereof, including parts, at the sole discretion of ADJ Products, LLC. All products covered by this warranty were manufactured after August 15, 2012, and bear identifying marks to that effect.
- E. ADJ Products, LLC reserves the right to make changes in design and/or improvements upon its products without any obligation to include these changes in any products theretofore manufactured.
- F. No warranty, whether expressed or implied, is given or made with respect to any accessory supplied with products described above. Except to the extent prohibited by applicable law, all implied warranties made by ADJ Products, LLC in connection with this product, including warranties of merchantability or fitness, are limited in duration to the warranty period set forth above. And all warranties, whether expressed or implied, including warranties of merchantability or fitness, are limited in duration to the warranty period set forth above. The consumer's and/or dealer's sole remedy shall be such repair or replacement as is expressly provided above; and under no circumstances shall ADJ Product, LLC be liable for any loss and/or damage, direct and/or consequential arising out of the use of, and/or inability to use this product.
- G. This warranty is the only written warranty applicable to ADJ Products, LLC products, and supersedes all prior warranties and written descriptions of warranty terms and conditions heretofore published.

MANUFACTURER'S LIMITED WARRANTY PERIODS:

- Non-LED Lighting Products = 1-Year (365 Days) (Including Special Effect Lighting, Intelligent Lighting, UV lighting, Strobes, Fog Machines, Bubble Machines, Mirror Balls, Par Cans, Trussing, Lighting Stands, Power/Data Distribution, etc. excluding LED and lamps)
- Laser Products = 1-Year (365 Days) (excluding laser diodes which have a 6-Month Limited Warranty)
- LED Products = 2-Year (730 Days) (excluding batteries which have a 180 Day Limited Warranty)
- NOTE: 2-Year (730 Days) Limited Warranty ONLY applies to product purchased within the United States. StarTec Series = 1-Year (365 Days) (excluding batteries which have a 180 Day Limited Warranty)
- ADJ DMX Controllers = 2 Year (730 Days)
- American Audio Products = 1 Year (365 Days)

WARRANTY REGISTRATION

The 12P Hex IP carries a 2 year (730 days) limited warranty. Please fill out the enclosed warranty card to validate your purchase. All returned service items, whether under warranty or not, must be freight pre-paid and accompanied by a return authorization (R.A.) number. The R.A. number must be clearly written on the outside of the return package. A brief description of the problem, as well as the R.A. number, must also be written down on a piece of paper included in the shipping carton. If the unit is under warranty, you must provide a copy of your proof of purchase invoice. You may obtain an R.A. number by contacting our customer support team on our customer support number. All packages returned to the service department not displaying an R.A. number on the outside of the package will be returned to the shipper.

FEATURES

- Multi-Colors
- Five Operating Modes
- Electronic Dimming 0-100%
- DMX-512 protocol
- IP65 Locking 5-Pin XLR Connections In/Out
- Four DMX Modes: 6, 7, 8, and 13-channel modes
- Multiple Unit Power Linking (See ***Multiple Unit Power Linking*** section of this manual)

INCLUDED ITEMS

- IP65 Locking Power Cable (x1)

INSTALLATION

The unit should be mounted using a mounting clamp (not provided), and affixing it to the mounting bracket that is provided with the unit. Always ensure that the unit is firmly fixed to avoid vibration and slipping during operation. Always ensure that the structure to which you are attaching the unit is secure and is able to support at least 10 times the unit's weight. Always use a safety cable that can hold at least 12 times the weight of the unit when installing the fixture. The equipment must be installed by a professional, and it must be installed in a place where it is out of the reach of the general public.

Ensure ALL connections and end caps are properly sealed with a non-conductive dielectric grease (available at most electronics suppliers) to prevent water ingress/condensation and/or corrosion.

SAFETY PRECAUTIONS

- Do not attempt to operate this unit if the power cord has been frayed or broken.
- Do not attempt to remove or break off the ground prong from the electrical cord. This prong is used to reduce the risk of electrical shock and fire in the event of an internal short.
- Disconnect from main power before making any type of connection.
- Do not remove the cover for any reason. There are no user serviceable parts inside.
- Never operate this unit with the cover removed.
- Never plug this unit in to a dimmer pack
- Always be sure to mount this unit in an area that will allow proper ventilation. Allow about 6” (15cm) between this device and a wall.
- Do not attempt to operate this unit if it has been damaged in any way.
- During long periods of non-use, disconnect the unit’s main power.
- Always mount this unit in safe and stable matter.
- Power-supply cords should be routed so that they are not likely to be walked on or pinched by items placed upon or against them, paying particular attention to the point at which the cords exit from the unit.
- **Cleaning** - The fixture should be cleaned only as recommended by the manufacturer. See the **Cleaning** section of this manual for details.
- **Heat** - The appliance should be situated away from heat sources such as radiators, heat registers, stoves, or other appliances (including amplifiers) that produce heat.
- The fixture should be serviced by qualified service personnel when:
 - A. The power supply cord or plug have been damaged.
 - B. Objects have fallen onto, or liquid has been spilled into, the device.
 - C. The appliance does not appear to operate normally, or exhibits a marked change in performance.
 - D. The fixture has fallen and/or been subjected to extreme handling.

SAFETY PRECAUTIONS



**HIGH
INTENSITY
ULTRAVIOLET
LIGHT**

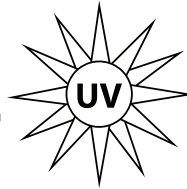

**AVOID DIRECT EYE & SKIN EXPOSURE.
WEAR PROPER EYE & SKIN PROTECTION.
SEE MANUAL FOR SAFETY INSTRUCTIONS.**

RISK GROUP 3 - RISK OF EXPOSURE TO ULTRAVIOLET (UV) RADIATION!

FIXTURE EMITS HIGH INTENSITY ULTRAVIOLET (UV) LIGHT FROM THE UV LED.

WEAR PROPER EYE AND SKIN PROTECTION.

AVOID PROLONGED PERIODS OF EXPOSURE TO THE UV LED.

AVOID WEARING WHITE COLOR CLOTHING AND/OR USING (UV) PAINTS ON SKIN.

AVOID DIRECT EYE AND/OR SKIN EXPOSURE AT DISTANCES SHORTER THAN 11 feet (3.3m).

DO NOT OPERATE FIXTURE WITH DAMAGED OR MISSING EXTERNAL COVER.

DO NOT LOOK DIRECTLY INTO THE (UV) LIGHT AND/OR VIEW (UV) LIGHT DIRECTLY WITH OPTICAL INSTRUMENTS THAT MAY CONCENTRATE THE LIGHT/RADIATION OUTPUT.

INDIVIDUALS SUFFERING FROM A RANGE OF EYE CONDITIONS, SUNLIGHT EXPOSURE DISORDERS, OR INDIVIDUALS USING PHOTSENSITIVE MEDICATION MAY EXPERIENCE DISCOMFORT IF EXPOSED TO THE ULTRAVIOLET (UV) LIGHT EMITTED FROM THIS FIXTURE.

IP NOTICE

IP65 RATED

An IP rated lighting fixture is commonly installed in outdoor environments and has been designed with an enclosure that effectively protects the ingress (entry) of external foreign objects such as dust and water. The International Protection (IP) rating system is commonly expressed as “IP” followed by two numbers (i.e. IP65), where the numbers define the degree of protection. The first digit (Foreign Bodies Protection) indicates the extent of protection against particles entering the fixture, and the second digit (Water Protection) indicates the extent of protection against water entering the fixture. ***An IP65 rated lighting fixture, such as this device, has been designed and tested to protect against the ingress of dust (6) and low-pressure water jets from any direction (5).***

MARINE/COASTAL ENVIRONMENT INSTALLATIONS



Although this fixture is IP rated, it is NOT suitable for marine and/or coastal environment installations. Installing this fixture in a marine and/or coastal environment may cause corrosion and/or excessive wear to the interior and/or exterior components of the fixture. Damage and/or performance issues resulting from installation in a marine and/or coastal environment will void the manufacturer’s warranty and will NOT be subject to any warranty claims and/or repairs.

OPTIONAL CORROSION RESISTANT COATING

Optional Corrosion-Resistant Coatings may be available for this fixture. Please consult your ADJ Products, LLC sales representative for details.

LAYOUT

- LCD Screen
- Mode Button
- Up Button
- Down Button
- Enter Button

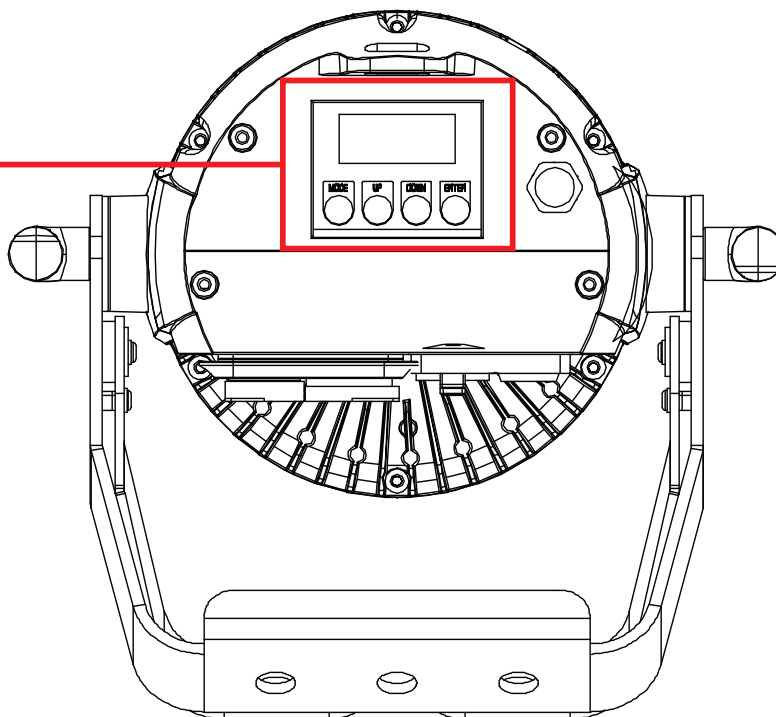

- IP65 Locking Power Connection In/Out
- IP65 Locking 5-Pin XLR Connector In/Out

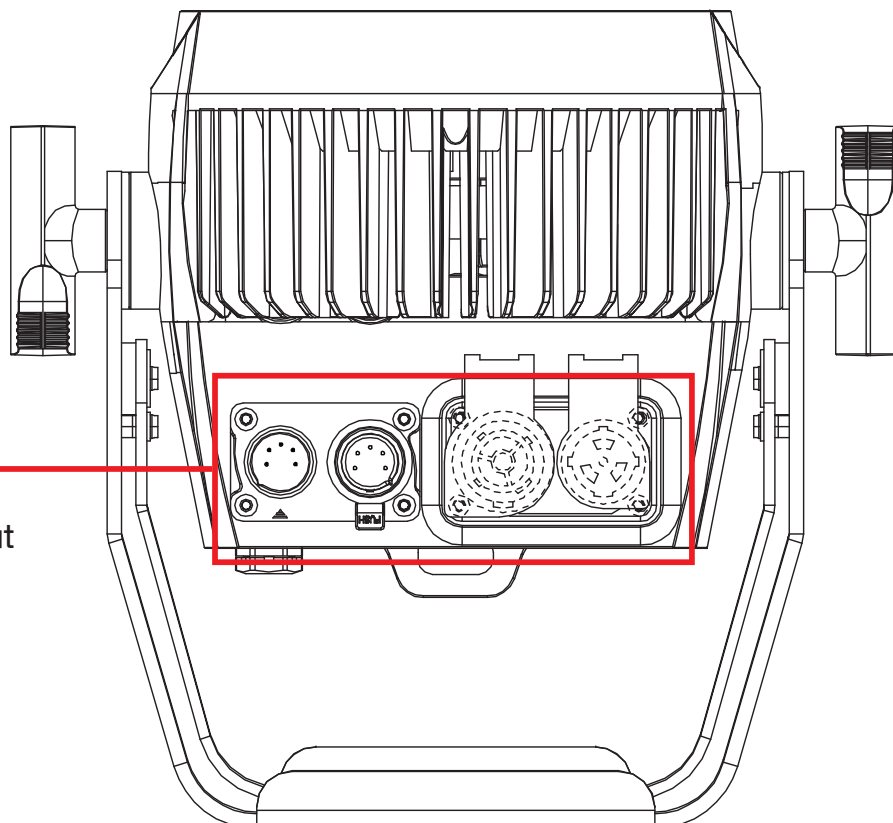

REMOTE DEVICE MANAGEMENT (RDM)

NOTE: In order for RDM to work properly, RDM enabled equipment must be used throughout the entire system, including DMX data splitters and wireless systems.

Remote Device Management (RDM) is a protocol that sits on top of the DMX512 data standard for lighting, allowing the DMX systems of the fixtures to be modified and monitored remotely. This protocol is ideal for instances in which a unit is installed in a location that is not easily accessible.

With RDM, the DMX512 system becomes bi-directional, allowing a compatible RDM enabled controller to send out a signal to devices on the wire, as well as allowing the fixture to respond (known as a *GET* command). The controller can then use its *SET* command to modify settings that would typically have to be changed or viewed directly via the unit's display screen, including the DMX Address, DMX Channel Mode, and Temperature Sensors.

FIXTURE RDM INFORMATION:

RDM Code	Device ID	Device Model ID	Personality ID
0x1900	7DCB	2321	001 6CH 002 7CH 003 8CH 004 13CH

Please be aware that **not all RDM devices support all RDM features**, and therefore it is important to check beforehand to ensure that the equipment that you are considering includes all of the features that you require.

The following parameters are accessible in RDM on this device:

Sensor Definition
Sensor Value
Device Model Description
Manufacturer Label
Device Label
DMX Personality
DMX Personality Description
Device Hours

DMX SET UP

DMX-512: DMX is short for Digital Multiplex. This is a universal protocol used as a form of communication between intelligent fixtures and controllers. A DMX controller sends DMX data instructions from the controller to the fixture. DMX data is sent as serial data that travels from fixture to fixture via the DATA “IN” and DATA “OUT” XLR terminals located on all DMX fixtures (most controllers only have a DATA “OUT” terminal).

DMX Linking: DMX is a language allowing all makes and models of different manufacturers to be linked together and operate from a single controller, as long as all fixtures and the controller are DMX compliant. To ensure proper DMX data transmission, try to use the shortest cable path possible when linking several DMX fixtures. The order in which fixtures are connected in a DMX line does not influence the DMX addressing. For example, a fixture assigned a DMX address of 1 may be placed anywhere in a DMX line: at the beginning, at the end, or anywhere in the middle. When a fixture is assigned a DMX address of 1, the DMX controller knows to send DATA assigned to address 1 to that unit, no matter where it is located in the DMX chain.

Data Cable (DMX Cable) Requirements (For DMX Operation): This device can be controlled via DMX-512 protocol, and features 4 selectable DMX channel modes. The DMX address is assigned using the display screen and controls on the back of the device. Your unit and your DMX controller require a 5-pin XLR connector for data input and data output. We recommend Accu-Cable DMX cables. If you are making your own cables, be sure to use standard 110-120 Ohm shielded cable (This cable may be purchased at almost all pro lighting stores). Your cables should be made with a male XLR connector at one end and a female XLR connector at the other. Also remember that DMX cable must be daisy chained and cannot be split.

Special Note: Line Termination. When longer runs of cable are used, it may be necessary to use a terminator on the last unit to avoid erratic behavior. A terminator is a 110-120 ohm 1/4 watt resistor which is connected between pins 2 and 3 of a male XLR connector (DATA + and DATA -). This unit is inserted in the female XLR connector of the last unit in your daisy chain to terminate the line. Using a cable terminator (ADJ part number Z-DMX/T) will decrease the possibilities of erratic behavior.

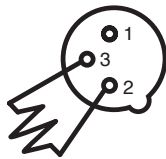

Termination reduces signal errors and avoids signal transmission problems and interference. It is always advisable to connect a DMX terminal, (Resistance 120 Ohm 1/4 W) between PIN 2 (DMX-) and PIN 3 (DMX +) of the last fixture.

DMX ADDRESSING

All fixtures should be given a DMX starting address when using a DMX controller, so that the correct fixture responds to the correct control signal. This digital starting address is the channel number from which the fixture starts to “listen” to the digital control signal sent out from the DMX controller. The starting DMX address is assigned using the digital control display on the back of the fixture.

You can set the same starting address for all fixtures or a group of fixtures, or set different addresses for each individual fixture. Setting all fixtures to the same DMX address will cause all fixtures to react in the same way; in other words, changing the settings of one channel will affect all the fixtures simultaneously.

If you set each fixture to a different DMX address, each unit will start to “listen” to the channel number you have set, based on the quantity of DMX channels of each fixture. That means changing the settings of one channel will only affect the selected fixture.

For example, when operating this unit in 6 channel mode, you should set the starting DMX address of the first unit to 1, the second unit to 7 (1 + 6), the third unit to 13 (1 + 6 + 6), and so on. See the chart below for more details.

CHANNEL MODE	UNIT 1 ADDRESS	UNIT 2 ADDRESS	UNIT 3 ADDRESS	UNIT 4 ADDRESS
6 CH	1	7	13	19
7 CH	1	8	15	22
8 CH	1	9	17	25
13 CH	1	14	27	40

DMX TRAITS

CHANNEL				DMX VALUES	FUNCTION
6 CH	7 CH	8 CH	13 CH		
1	1	1	1	000 - 255	Red , 0% to 100%
2	2	2	2	000 - 255	Green , 0% to 100%
3	3	3	3	000 - 255	Blue , 0% to 100%
4	4	4	4	000 - 255	White , 0% to 100%
5	5	5	5	000 - 255	Amber , 0% to 100%
6	6	6	6	000 - 255	UV , 0% to 100%
	7	7	7	000 - 255	Master Dimmer , 0% to 100%
					Strobe
				000 - 031	LED Off
				032 - 063	LED On
				064 - 095	Strobe, slow to fast
		8	8	096 - 127	LED On
				128 - 159	Strobe Pulse, slow to fast
				160 - 191	LED On
				192 - 223	Random Strobe
				224 - 255	LED On
			9	000 - 255	Color Macro , see Color Macro Chart section of this manual
					Auto Programs
				000 - 019	No Function
				020 - 039	Program 1
				040 - 059	Program 2
				060 - 079	Program 3
				080 - 099	Program 4
				100 - 119	Program 5
			10	120 - 139	Program 6
				140 - 159	Program 7
				160 - 179	Program 8
				180 - 199	Program 9
				200 - 219	Program 10
				220 - 239	Program 11
				240 - 255	Program 12
			11	000 - 255	Auto Program Speed , slow to fast
			12	000 - 255	Auto Program Fade , slow to fast

CONTINUED ON NEXT PAGE

DMX TRAITS

CHANNEL				DMX VALUES	FUNCTION
6 CH	7 CH	8 CH	13 CH		
			13		<i>Dimmer Modes</i>
				000 - 020	Standard
				021 - 040	Stage
				041 - 060	TV
				061 - 080	Architectural
				081 - 100	Theatre
				101 - 255	Default to unit setting

COLOR MACRO CHART

COLOR NO.	DMX VALUES	COLOR INTENSITY					
		RED	GREEN	BLUE	WHITE	AMBER	UV
Off	000	0	0	0	0	0	0
Color1	001 - 004	80	255	234	80	0	0
Color2	005 - 008	80	255	164	80	0	0
Color3	009 - 012	77	255	112	77	0	0
Color4	013 - 016	117	255	83	83	0	0
Color5	017 - 020	160	255	77	77	0	0
Color6	021 - 024	223	255	83	83	0	0
Color7	025 - 028	255	243	77	77	0	0
Color8	029 - 032	255	200	74	74	0	0
Color9	033 - 036	255	166	77	77	0	0
Color10	037 - 040	255	125	74	74	0	0
Color11	041 - 044	255	97	77	74	0	0
Color12	045 - 048	255	71	77	71	0	0
Color13	049 - 052	255	83	134	83	0	0
Color14	053 - 056	255	93	182	93	0	0
Color15	057 - 060	255	96	236	96	0	0
Color16	061 - 064	238	93	255	93	0	0
Color17	065 - 068	196	87	255	87	0	0
Color18	069 - 072	150	90	255	90	0	0
Color19	073 - 076	100	77	255	77	0	0
Color20	077 - 080	77	100	255	77	0	0
Color21	081 - 084	67	148	255	67	0	0
Color22	085 - 088	77	195	255	77	0	0
Color23	089 - 092	77	234	255	77	0	0
Color24	093 - 096	158	255	144	144	0	0
Color25	097 - 100	255	251	153	153	0	0
Color26	101 - 104	255	175	147	147	0	0
Color27	105 - 108	255	138	186	138	0	0
Color28	109 - 112	255	147	251	147	0	0
Color29	113 - 116	151	138	255	138	0	0
Color30	117 - 120	100	138	255	138	0	0
Color31	121 - 124	138	169	255	138	0	0
Color32	125 - 128	255	255	255	255	0	0
Color33	129 - 132	255	206	143	0	0	0
Color34	133 - 136	254	177	153	0	0	0
Color35	137 - 140	254	192	138	0	0	0
Color36	141 - 144	254	165	98	0	0	0
Color37	145 - 148	254	121	0	0	0	0
Color38	149 - 152	176	17	0	0	0	0
Color39	153 - 156	96	0	11	0	0	0

COLOR MACRO CHART

COLOR NO.	DMX VALUES	COLOR INTENSITY					
		RED	GREEN	BLUE	WHITE	AMBER	UV
Color40	157 - 160	234	139	171	0	0	0
Color41	161 - 164	224	5	97	0	0	0
Color42	165 - 168	175	77	173	0	0	0
Color43	169 - 172	119	130	199	0	0	0
Color44	173 - 176	147	164	212	0	0	0
Color45	177 - 180	88	2	163	0	0	0
Color46	181 - 184	0	38	86	0	0	0
Color47	185 - 188	0	142	208	0	0	0
Color48	189 - 192	52	148	209	0	0	0
Color49	193 - 196	0	46	35	0	0	0
Color50	197 - 200	8	107	222	0	0	0
Color51	201 - 204	107	156	231	0	0	0
Color52	205 - 208	165	198	247	0	0	0
Color53	209 - 212	0	83	115	0	0	0
Color54	213 - 216	0	97	166	0	0	0
Color55	217 - 220	1	100	167	0	0	0
Color56	221 - 224	0	40	86	0	0	0
Color57	225 - 228	209	219	182	0	0	0
Color58	229 - 232	42	165	85	0	0	0
Color59	233 - 236	255	0	0	0	0	0
Color60	237 - 240	0	255	0	0	0	0
Color61	241 - 244	0	0	255	0	0	0
Color62	245 - 248	0	0	0	255	0	0
Color63	249 - 252	0	0	0	0	255	0
Color64	253 - 255	0	0	0	0	0	255

SYSTEM MENU (V1.04)

Display Menu	Update Wait... ADJ Vx.xx				
Menu Set ADDR	Set ADDR xxx	001 - 506 DMX Addressing			
Menu User Mode	CHxx	06	DMX Channel Modes		
		07			
		08			
		13			
Menu Function	DimCurve	Standard		Dimmer Curve Setting	
		Stage			
		TV			
		Architec			
		Theatre			
	NODMX	Hold		DMX Lost Setting	
		Blackout			
		Program			
	AUTO RUN FQN:xx	01 - 99		Auto Run Programs	
	STATC CL:x	Red	STR: 000 - 255	Static Color Mode	
		Green			
		Blue			
		Red + Green			
		Green + Blue			
		Red + Blue			
		Red + Green + Blue			
		Black			
	Macros xx	00 - 64		Color Macro Mode	
	LCD.Set	Backlight	05m - 60m		LCD Display Settings
		Key Lock	On / On1 / Off		
Dis Flash		On / Off			
DFSET	On / Off		Default Reset		
TEMP	Fahren / Celsius		Temperature Display Units		
Settings WhiteBal	Red	000 - 255		White Balance Setting	
	Green	000 - 255			
	Blue	000 - 255			
	White	000 - 255			
	Amber	000 - 255			
	UV	000 - 255			

CONTINUED ON NEXT PAGE

SYSTEM MENU (V1.04)

Menu Function (continued)	Fre_hz	900 , 1000, 1100, 1200, 1300, 1400, 1500, 2500, 4000, 5000, 10k, 15k, 20k, 25k		Set LED Refresh Frequency Rate
	Gamma	2.0		Set Gamma Brightness
		2.2		
		2.4		
		2.8		
Menu Info	Info Time Info	Time Info Current		Current Running Time (Hours)
		Time Info Total Tim		Total Time (Hours)
		Time Info Last Clea		Last Time Running Hours Were Cleared (Hours)
		Time Info Timer PIN	Clear 0 Password = 050	
	Total Time Clear 0 Password = 060			
	Info Temp Info	Temp Info xxx		Current Running Temperature
	Info Model Inf			Model Name
Info Software	Vx.xx		Current Software Version	
Info Error Inf			Error Information	
Menu Secondary	Secondary			Secondary Mode Setting
Menu Manual	Man Ctrl Dimmer	000 - 255		Manual Control
	Man Ctrl Red	000 - 255		
	Man Ctrl Green	000 - 255		
	Man Ctrl Blue	000 - 255		
	Man Ctrl White	000 - 255		
	Man Ctrl Amber	000 - 255		
	Man Ctrl Purple	000 - 255		
	Man Ctrl Strobe	000 - 255		

SYSTEM MENU (V1.07)

Display Menu	Update Wait... ADJ Vx.xx			
Menu Set ADDR	Set ADDR xxx	001 - 506 DMX Addressing		
Menu User Mode	CHxx	06	DMX Channel Modes	
		07		
		08		
		13		
Menu Function	Dim Mode	Standard	Dimmer Mode Setting	
		Stage		
		TV		
		Architec		
		Theatre		
	NODMX	Hold	DMX Lost Setting	
		Blackout		
		Program		
	AUTO RUN FQN:xx	01 - 99 Auto Run Programs		
	STATC CL:x	Red	STR: 000 - 255	Static Color Mode
		Green		
		Blue		
		Red + Green		
		Green + Blue		
		Red + Blue		
		Red + Green + Blue		
		Black		
	Macros xx	00 - 64 Color Macro Mode		
	LCD Set	Backlight	05m - 60m	LCD Display Settings
Key Lock		On / On1 / Off		
Dis Flash		On / Off		
DFSET	On / Off Default Reset			
TEMP	Fahren / Celsius Temperature Display Units			
Settings WhiteBal	Red	000 - 255	White Balance Setting	
	Green	000 - 255		
	Blue	000 - 255		
	White	000 - 255		
	Amber	000 - 255		
	UV	000 - 255		

CONTINUED ON NEXT PAGE

SYSTEM MENU (V1.07)

Menu Function (continued)	Fre_hz	900, 1000, 1100, 1200, 1300, 1400, 1500, 2500, 4000, 5000, 10k, 15k, 20k, 25k		Set LED Refresh Frequency Rate
	Dim Curve	Linear		Set Dimming Curve
		Square		
		Inv Squa		
S-Curve				
Menu Info	Info Time Info	Time Info Current		Current Running Time (Hours)
		Time Info Total Tim		Total Time (Hours)
		Time Info Last Clea		Last Time Running Hours Were Cleared (Hours)
		Time Info Timer PIN	Clear 0 Password = 050	
	Total Time Clear 0 Password = 060			
	Info Temp Info	Temp Info xxx		Current Running Temperature
	Info Model Inf			Model Name
Info Software	Vx.xx		Current Software Version	
Info Error Inf			Error Information	
Menu Secondary	Secondary			Secondary Mode Setting
Menu Manual	Man Ctrl Dimmer	000 - 255		Manual Control
	Man Ctrl Red	000 - 255		
	Man Ctrl Green	000 - 255		
	Man Ctrl Blue	000 - 255		
	Man Ctrl White	000 - 255		
	Man Ctrl Amber	000 - 255		
	Man Ctrl Purple	000 - 255		
	Man Ctrl Strobe	000 - 255		

OPERATING INSTRUCTIONS

DMX Addressing: Operating through a DMX controller gives the user the freedom to create custom programs tailored to his or her own needs. This device offers 4 DMX modes: 6 Channel mode, 7 Channel mode, 8 Channel mode, and a 13 Channel mode.

1. To run your fixture in DMX mode, press the MODE button, and then press the UP or DOWN buttons until “Menu Set Addr” is displayed.
2. Press ENTER. The current DMX address will now be displayed. Use the UP or DOWN buttons to find your desired DMX address, and press ENTER to confirm. Please refer to the **DMX Traits** section of this manual for detailed information.

DMX Channel Mode: Select your desired DMX channel mode.

1. Access the main menu, and press the UP or DOWN buttons so that “Menu User Mode” is highlighted, then press ENTER.
2. Press the UP or DOWN buttons to scroll through the 4 DMX channel modes. When you have found your desired DMX channel mode, press ENTER.
3. Press the MODE button to return to the main menu.

Dimmer Mode Setting:

1. Access the main menu, and press the UP or DOWN buttons so that “Menu Function” is highlighted, then press ENTER.
2. Press the UP or DOWN buttons so that “Dim Mode” is highlighted. Press ENTER.
3. Use the UP and DOWN buttons to scroll through the 5 available dimmer mode settings, and press ENTER to select your desired option. Please see the **Dimmer Mode Chart** section of this manual for detailed information.

DMX State: Defines how the fixture will behave in the event that the DMX signal is lost or interrupted. Also defines the mode the fixture will start in when first powered on.

1. Access the main menu, and press the UP or DOWN buttons so that “Menu Function” is highlighted, then press ENTER.
2. Press the UP or DOWN buttons so that “NODMX” is highlighted, then press ENTER.
3. Use the UP and DOWN buttons to scroll through the 3 DMX standing states.
 - “Hold” - The fixture will stay in the last DMX set up.
 - “Blackout” - The fixture will automatically go into stand by mode.
 - “Program” - The fixture will automatically go into Auto Run mode.
4. Use the UP and DOWN buttons to find your desired DMX state, and then press ENTER to confirm, or press MODE to exit without making changes.

Auto Run Mode:

1. Access the main menu, and press the UP or DOWN buttons so that “Menu Function” is highlighted, then press ENTER.
2. Use the UP or DOWN buttons to highlight “AUTO RUN FQN” and press ENTER.
3. Use the UP or DOWN buttons to scroll through the 99 Auto Run programs. Press ENTER to confirm your selection.

OPERATING INSTRUCTIONS

Static Color Mode:

1. Access the main menu, and press the UP or DOWN buttons so that “Menu Function” is highlighted, then press ENTER.
2. Use the UP or DOWN buttons to highlight “1. STATC CL:X” and press ENTER. “X” is the current color that is displayed.
3. Use the UP or DOWN buttons to scroll through the static color choices, and press ENTER to confirm your selection and move on to the strobe function set up.
4. Use the UP and DOWN buttons to adjust the strobe rate. Press ENTER after you have found your desired strobe rate.

Color Macro Mode:

1. Access the main menu and press the UP or DOWN buttons until “Menu Function” is displayed, and then press ENTER.
2. Press the UP or DOWN buttons until “Macros” is displayed and press ENTER.
3. There are 64 colors to choose from. Find your desired color using the UP and DOWN buttons. Once you have found your desired color press ENTER.

LCD Display Settings:

1. Access the main menu and press the UP or DOWN buttons until “Menu Function” is displayed, and press ENTER.
2. Press the UP or DOWN buttons until “LCD.Set” is displayed and press ENTER.
3. Use the UP and DOWN buttons to select from the 3 LCD Display settings options, then press ENTER to select an option. Use the UP and DOWN options to make adjustments, and press ENTER to move on to the next setting.
 - “Backlight” - This lets you set how long the backlight display will stay on.
 - “Key Lock” - This lets you control the key lock feature.
 - “ON” - Press the MODE button for 10 seconds to unlock the keypad.
 - “OFF” - The keypad is unlocked, simply press the MODE button to activate the keypad.
 - “ON1” - This setting is used to prevent the accidental unlocking of the keypad. To unlock the keypad you will have to enter a passcode. Press the MODE button and the display will show “LOCKED *****”. To unlock the keypad press UP, DOWN, UP, DOWN, & ENTER in that order.
 - “DisFlash” - Display flash.

Default Running Mode: When this mode is activated, all settings will revert to their original factory default settings.

1. Access the main menu and press the MODE button and press the UP or DOWN buttons until “Menu Function” is displayed, and press ENTER.
2. Press the UP or DOWN buttons until “DFSET” displayed, and press ENTER.
3. Use the UP or DOWN button to toggle between “ON” and “OFF”, press ENTER to make your selection. Press the MODE button to exit without making changes.

OPERATING INSTRUCTIONS

Unit Temperature: Switch the temperature units between Celsius and Fahrenheit.

1. Access the main menu and press the UP or DOWN buttons until “Menu Function” is displayed, and then press ENTER.
2. Press the UP or DOWN buttons until “Temp” is displayed and press ENTER.
3. Use the UP and DOWN buttons to switch between “Fahren” and “Celsius”.
4. Press ENTER to confirm your selection.

White Balance Settings: Adjust RGBWA & UV colors to balance the white color.

1. Access the main menu and press the UP or DOWN buttons until “Menu Function” is displayed, and then press ENTER.
2. Press the UP or DOWN buttons until “Settings WhiteBal” is displayed and press ENTER.
3. Use the UP and DOWN buttons to switch between the colors. When you have found the color you wish to adjust, press ENTER, then use the UP or DOWN button to adjust the color values.
4. Press ENTER to confirm your selection.

Frequency Setting: Adjust the LED refresh rate.

1. Access the main menu and press the UP or DOWN buttons until “Menu Function” is displayed, and then press ENTER.
2. Press the UP or DOWN buttons until “Fre_hz” is displayed and press ENTER.
3. Use the UP and DOWN buttons to scroll through different frequencies.
4. Press ENTER to confirm your selection.

Gamma Brightness Setting: Adjust the gamma brightness. *Note: This setting was removed from the system menu starting with software version V1.07.*

1. Access the main menu and press the UP or DOWN buttons until “Menu Function” is displayed, and then press ENTER.
2. Press the UP or DOWN buttons until “Gamma” is displayed and press ENTER.
3. Use the UP and DOWN buttons to scroll through different settings.
4. Press ENTER to confirm your selection.

Dimmer Curve Setting: Select a dimmer curve. *Note: This setting was added to the main menu with software version V1.07.*

1. Access the main menu, and press the UP or DOWN buttons so that “Menu Function” is highlighted, then press ENTER.
2. Press the UP or DOWN buttons so that “Dim Mode” is highlighted, then press ENTER.
3. Press the UP or DOWN buttons to scroll through the 4 available dimmer curve options, and press ENTER to select your desired choice. Please see the **Dimmer Curve Chart** section of this manual for detailed information.

OPERATING INSTRUCTIONS

Time Information:

1. Access the main menu and press the UP or DOWN buttons until “Menu Info” is displayed, and then press ENTER.
2. Press the UP or DOWN buttons to scroll through the different information menus. Press ENTER to access your desired menu and view the desired information.
 - “*Time Info*” - This will display information related to unit run time.
 - “*Temp Info*” - This will display the current running temperature
 - “*Model Inf*” - This will display the model name.
 - “*Error Inf*” - This will display any error information.
3. If selecting the “Time Info” option, the unit will present a number of sub-options to choose from. Use the UP and DOWN buttons to scroll through these sub-options, and press ENTER to select and view the desired information.
 - “*Time Info Current*” - This will display the current running time of the fixture in hours.
 - “*Time Info Total Tim*” - This will display the total running time of the fixture in hours.
 - “*Time Info Last Clea*” - This will display the last time the running time was cleared.
 - “*Time Info Timer PIN*” - This menu function will allow you to clear the running time.

Secondary Setting: Set the unit as a “Secondary” in Primary/Secondary configuration.

1. Access the main menu and press the UP or DOWN buttons until “Secondary” is displayed, and then press ENTER.
2. The unit is now set as a “Secondary” in a Primary-Secondary configuration.

Manual Control: Manually adjust all colors to create a custom color.

1. Access the main menu and press the UP or DOWN buttons until “Menu Manual” is displayed, and then press ENTER.
2. Press the UP or DOWN buttons to scroll through the different manual control parameters. Press ENTER to select a parameter, then use the UP and DOWN buttons to make adjustments.
3. Once you have made your desired adjustments, press ENTER to confirm.

PRIMARY-SECONDARY CONFIGURATION

This function the units to be linked together to run in a Primary-Secondary set-up, in which one unit will act as the controlling unit and the others will react to the controlling unit's built-in programs. Any unit can act as a Primary or as a Secondary, but only one unit in the system can be programmed to act as the "Primary."

Primary-Secondary Connections and Settings:

1. Daisy chain your units via the XLR connectors on the rear panel of each unit. Use standard XLR data cables to link your units together. Remember that the male XLR connector is the input, and the female XLR connector is the output. The first unit in the chain (primary) will use the female XLR connector only, and the last unit in the chain will use the male XLR connector only.
2. Connect the first "Secondary" unit to the "Primary." More "Secondary" units may be linked to the first "Secondary" if desired.
3. Set the "Primary" unit to your desired mode of operation. On each "Secondary" unit, press the MODE button and use the UP or DOWN buttons to scroll to "Menu Secondary" is displayed.
4. Press ENTER to set the unit as a "Secondary".

MULTIPLE UNIT POWER LINKING

This features allows fixtures to be linked to one another using the power input and output sockets.

The maximum number of units that can be connected in this manner is as follows:

- **12 fixtures @ 120V.**
- **24 fixtures @ 240V.**

After the maximum numbers of connected fixtures has been reached, a new power outlet will be required to accommodate any additional units.

NOTE: USE CAUTION WHEN POWER LINKING FIXTURES OF OTHER MAKE AND MODEL TYPES, AS THE POWER CONSUMPTION OF OTHER LIGHTING FIXTURES WILL VARY!

DIMMER MODE CHART

DIMMER

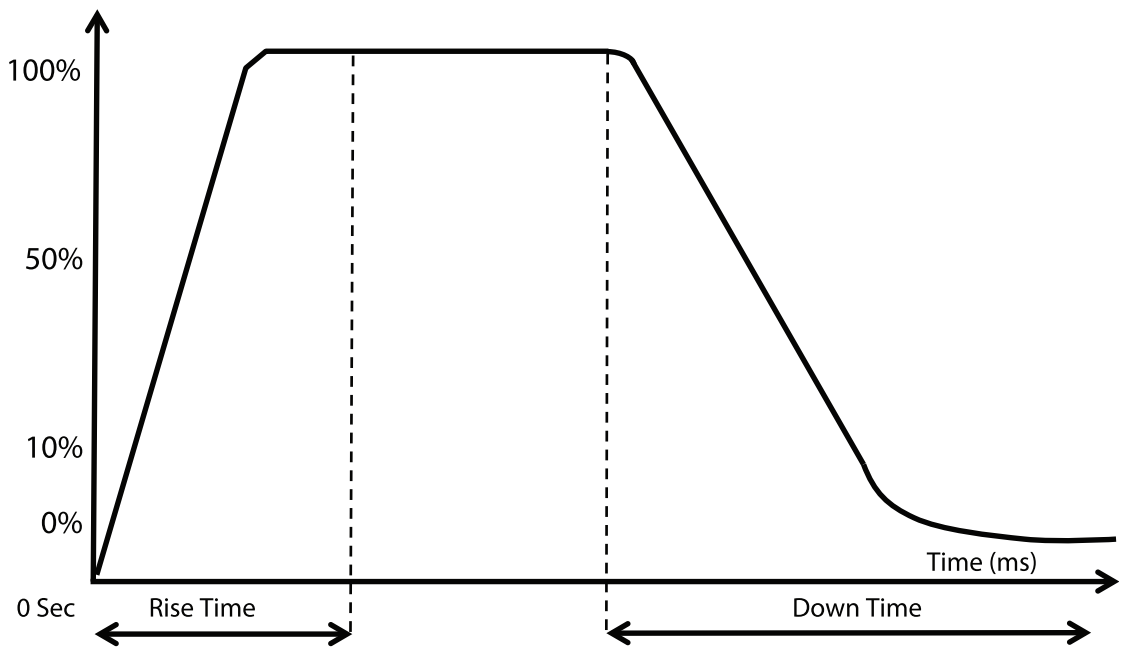

Dimming Mode Ramp Effect	0 sec Fade Time		1 sec Fade Time	
	Rise Time (ms)	Down Time (ms)	Rise Time (ms)	Down Time (ms)
Standard (default)	0	0	0	0
Stage	780	1100	1540	1660
TV	1180	1520	1860	1940
Architectural	1380	1730	2040	2120
Theatre	1580	1940	2230	2280

DIMMER CURVE CHART

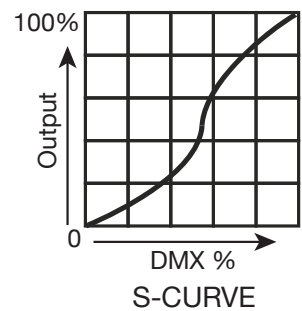
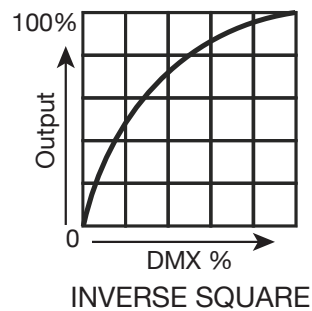
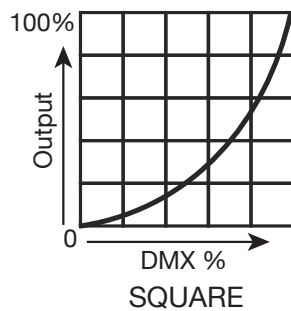
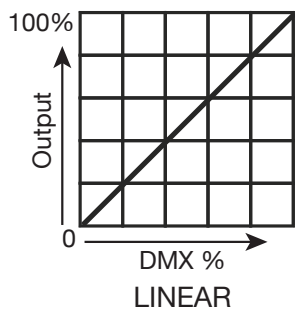

DIMENSIONAL DRAWING

***NOT TO SCALE**

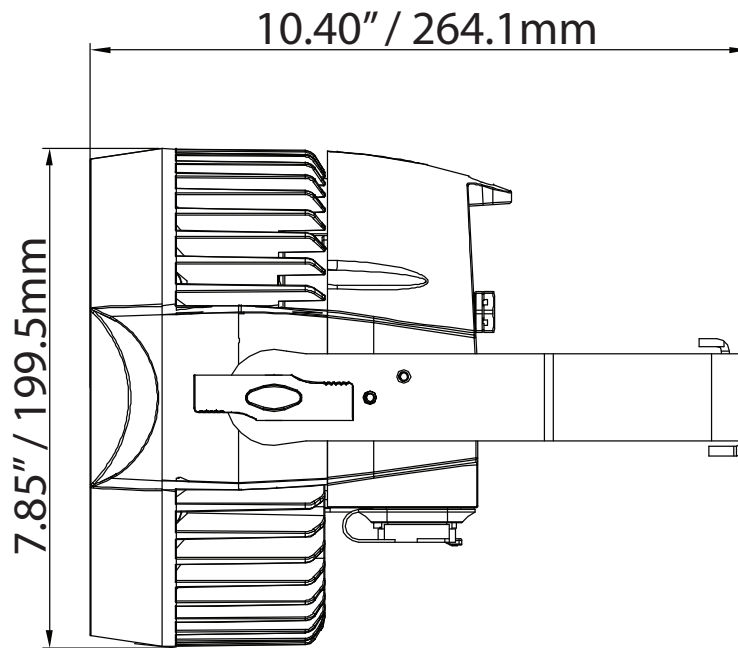
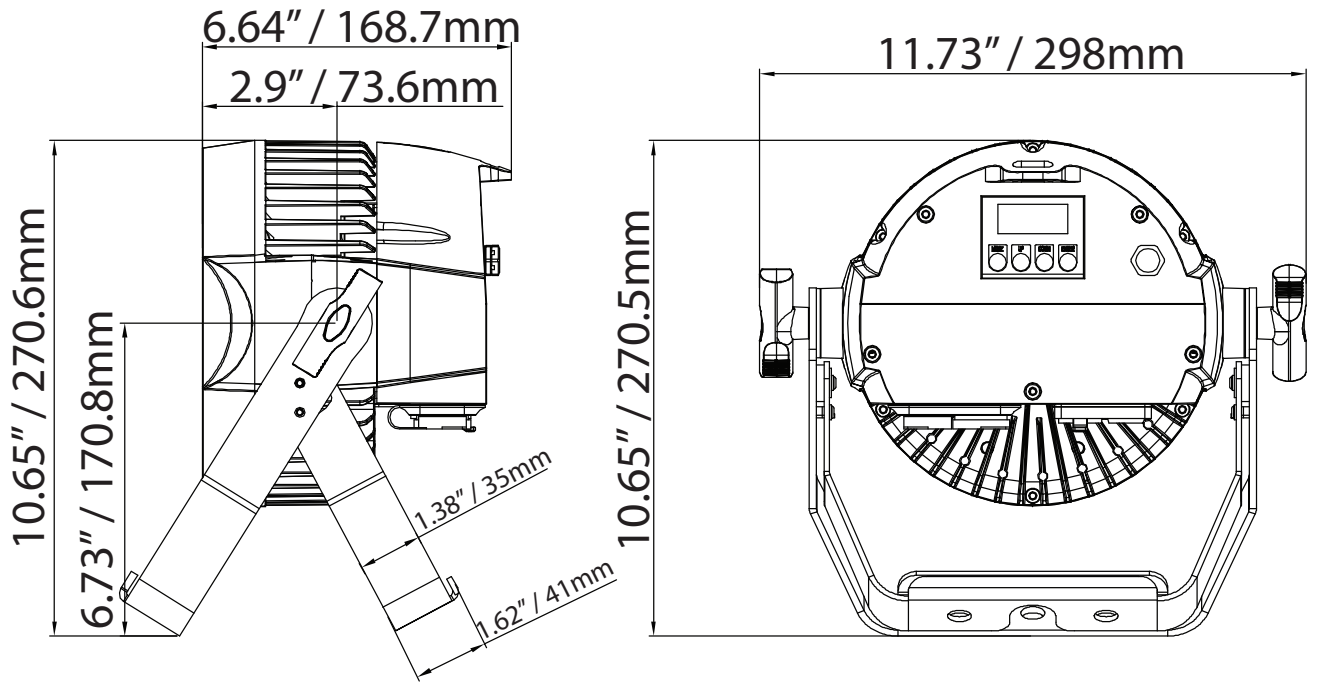

TROUBLE SHOOTING

Below is a common problem the user may encounter, with potential solutions.

Unit not responding to DMX:

Check that the DMX cables are connected and wired correctly (pin 3 is “hot”; on some other DMX devices, pin 2 may be “hot”). Also, check that all cables are connected to the right connectors, as the order in which inputs and outputs are connected will affect the operation of the device.

CLEANING

Due to fog residue, smoke, and dust, cleaning the internal and external optical lenses must be carried out periodically in order to optimize light output.

- Use normal glass cleaner and a soft cloth to wipe down the outside casing.
- Periodically clean the external optics with glass cleaner and a soft cloth.
- Always be sure to dry all parts completely before plugging the unit back in.

Cleaning frequency depends on the environment in which the fixture operates (i.e. smoke, fog residue, dust, dew).

SPECIFICATIONS

Optical:

- Light Source: 12 x 12-Watt RGBAW + UV LEDs (Red, Green, Blue, Amber, White & UV LED) - Rated at approximately 50,000 hrs.)
- Beam angle: 25-degree

Features:

- 5 Operational modes: Static Color Mode, RGBAW & UV Dimmer Mode, Program Mode, Sound Active Mode and DMX Controlled
- 63 built-in Color Macros
- Flicker Free operation (No flickering on camera)
- 5 selectable Dim Curves (Standard, Stage, TV, Architectural & Theatre)
- LED pulse and strobe effect
- Electronic Dimming: 0 - 100%
- Supports RDM (Remote Device Management)
- Scissor Yoke & safety eye

Connections:

- IP65 PowerLock AC In/Out connections
- IP65 Data linkable via 5-pin XLR cables
- Daisy chain: 12 units (120V); 24 units (220V)

Control:

- 4-button, DMX digital display on rear panel
- 4 DMX Modes: 6, 7, 8, & 13-channel

Dimensions / Weight:

- Dimensions (LxWxH): 11.75" x 7.85" x 10.5" / 298x199.5x264mm
- Weight: 10.5 lbs. / 4.7 kg.

Certifications:

- IP rating: IP65 Outdoor Rated

Please Note: Specifications and improvements in the design of this unit and this manual are subject to change without any prior written notice.

